

## 7794 DVP Sanitary Durafet® III pH Electrodes with Vario Pin Connector

## Specification

### Description

Honeywell introduces the Sanitary Durafet® III pH electrode, a non-glass, unbreakable, ISFET (Ion Sensitive Field Effect Transistor) technology based pH sensor. The Sanitary Durafet® III electrode is designed to meet 3-A Sanitary Standards. Solid state ISFET technology eliminates the conventional, fragile glass pH sensor. The unbreakable pH sensor can be inserted directly into the process without the fear of product contamination. pH measurement can be online and continuous—no time-consuming grab sampling is necessary. This pH electrode, with over 9 years of industry-proven application experience, provides fast, accurate and dependable pH measurement in the most demanding food and dairy applications.

The Sanitary Durafet® III pH electrode has an integral, tri-clamp flange for easy mounting in the process. Cable options available for remote mounting to the innovative Honeywell DirectLine® Sensor Module. It is also available with the Cap Adapter cable for connection to Honeywell instrumentation (APT and 9782 Series), as well as selected competitors' instrumentation. All cable options use the Vario Pin connector that provides an IP68, waterproof connection to the electrode.

### Features

- Designed to meet rigorous environmental requirements of the Food and Dairy industries.
- Authorized to use the 3-A symbol.
- Rugged – does not employ conventional glass membrane. Uses ISFET, solid state sensor.
- New Vario Pin quick disconnect, IP68 waterproof cable for easy electrode installation/replacement.

- New “no epoxy” packaging design for greater reliability
- Reference electrode and compensating temperature sensor integral with electrode.
- Remote mounting option for DirectLine® sensor.
- Connection capability to standard tri-clamp fittings.
- Choice of cable lengths: 20' or 50'.
- Six (6) models available with varying flange size and immersion lengths.

#### Cap Adapter

The Cap Adapter cable option is essentially a preamplifier that is an integral part of the electrode cable. It does not require separate mounting. The output from the Cap Adapter can be connected directly to a pH instrument (9782 or APT2000). It is available in lengths of 20' and 50'.



7794 Sanitary Durafet® III Electrode



Optional Cap Adapter

## Dimensions

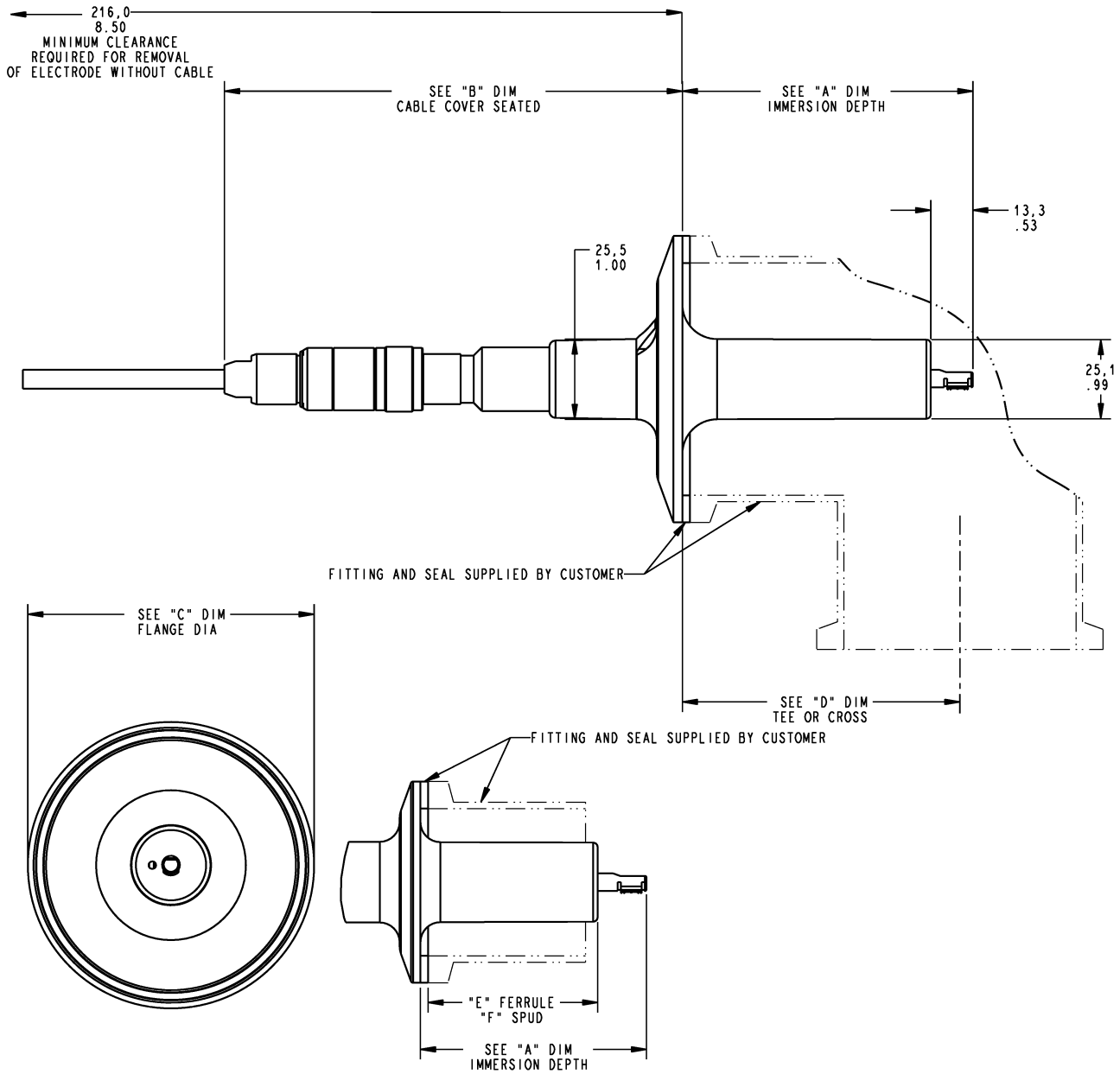

PART NO	CIP FLANGE	A DIM	B DIM	C DIM	D DIM	E DIM	F DIM
51453535-001	38,1 1.50	58,2 2.29	179,4 7.06	50,3 1.98	69,9 2.75	41,4 1.63	76,2 3.00
51453535-002		73,9 2.91	163,6 6.44				
51453535-003	50,8 2.00	71,9 2.83	165,6 6.52	64,0 2.52	88,9 3.50	44,5 1.75	76,2 3.00
51453535-004		94,5 3.72	143,0 5.63				
51453535-005	76,2 3.00	64,3 2.53	173,3 6.82	90,9 3.58	95,3 3.75	49,2 1.94	101,6 4.00
51453535-006		94,5 3.72	140,0 5.51				

## Specifications

Sanitary Durafet® III Electrode	
<b>Operating Range</b>	0-14 pH
<b>Operating Temperature Range</b>	-10 °C to 110 °C [14 °F to 230 °F]
<b>Sterilization Conditions (non-operating)</b>	130 °C maximum at 50 psig
<b>Maximum Process Pressure</b>	0 to 690 kPa from -10 °C to 100 °C 0 to 345 kPa @ >100 °C 0 to 100 psig from 14 °F to 212 °F 0 to 50 psig @ >212 °F
<b>Electrode Body</b>	Fortron®, FDA-compliant Polysulfone, FDA-compliant Ceramic reference junction Silicon ISFET measuring sensor Viton sensor seal
<b>Electrode Mounting</b>	Connects to standard CIP fittings, Tri-Clamp® or equivalent
<b>Cables</b>	DirectLine Remote Cable: 20 feet and 50 feet length Cap Adapter (for 9782P and APT Series): 20 feet and 50 feet length
<b>Electrical Connectio</b>	Vario Pin, IP68 rated
<b>Weight</b>	1-1/2": 181.7 g [6.4 oz.] 2": 190.3 g [6.7 oz.] 3": 229.9 g [8.1 oz.]

The Sanitary Durafet® III ISFET sensor lifetime is affected by exposure to hot caustic solutions that can be present in CIP cycles of Food and Dairy applications. The following graph can be used as a guideline to determine if the Sanitary Durafet® III pH electrode should be taken out of the process during the cleaning cycle. For expected lifetime at specific temperatures and caustic concentrations based on exposure time contact your local Honeywell Sales representative.

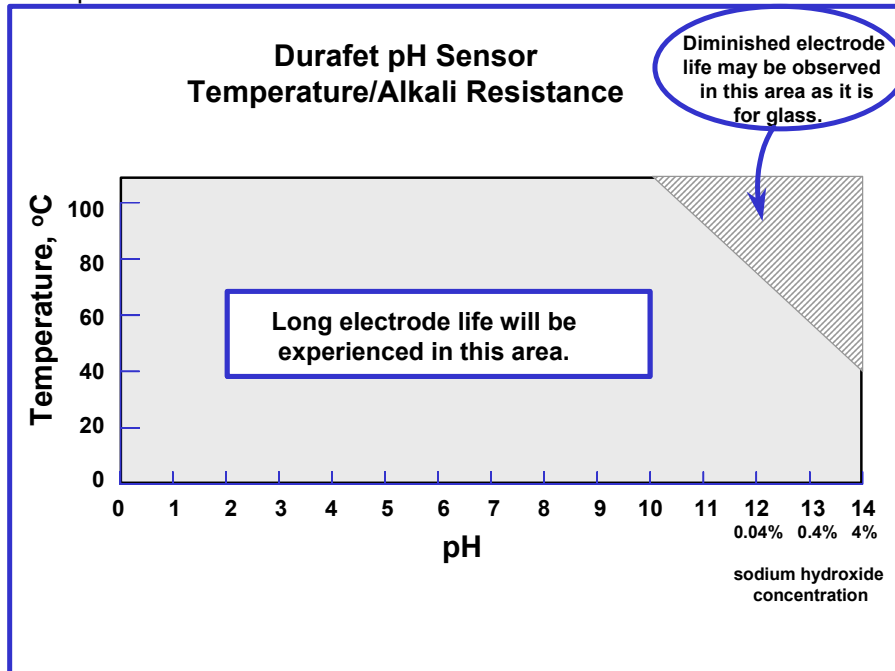

---

## Warranty/Remedy

---

Honeywell warrants goods of its manufacture as being free of defective materials and faulty workmanship. Contact your local sales office for warranty information. If warranted goods are returned to Honeywell during the period of coverage, Honeywell will repair or replace without charge those items it finds defective. The foregoing is Buyer's sole remedy and is **in lieu of all other warranties, expressed or implied, including those of merchantability and fitness for a particular purpose**. Specifications may change without notice. The information we supply is believed to be accurate and reliable as of this printing. However, we assume no responsibility for its use.

While we provide application assistance personally, through our literature and the Honeywell web site, it is up to the customer to determine the suitability of the product in the application.

Distributor :

For more information, contact Honeywell sales at 1-800-343-0228.

---

# Honeywell

### Industrial Measurement and Control

Honeywell  
1100 Virginia Drive  
Fort Washington, PA 19034